



REF.10

Waterfall in stainless steel AISI 316L (Marine quality). Polished finish.



Support
Included

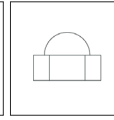

Nuts
Included

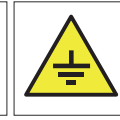

Earth
Connection

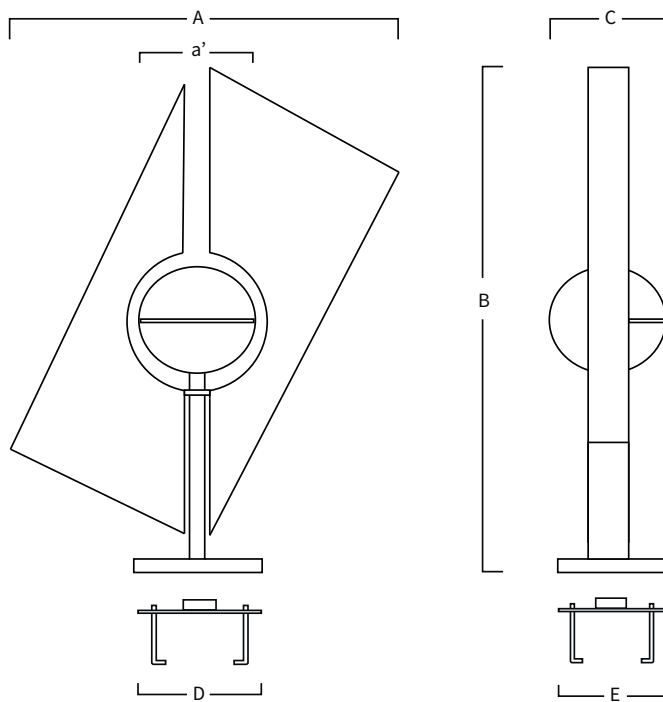

A	a'	B	C	D	E
850	330	1060	300	200	160

Measure in mm

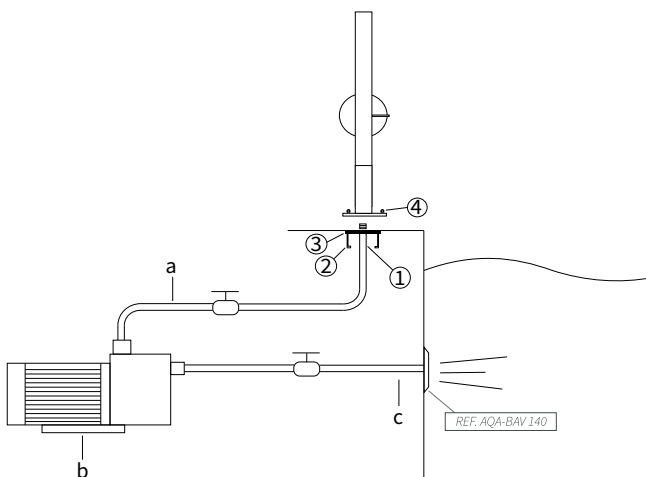

MOUNTING SYSTEM

- 1) Connect the water intake to the support with 1 1/2" female fitting.
- 2) Fix the earth connection to the support.
- 3) Embed the support to get the platen at ground level.
 - a) Impulsion tube (Ø50mm).
 - b) Self-priming pump:
10: 0,80hp - 10m³/h (Ref. AQA-B10).
 - c) Suction tube 2" (Ø63mm).

*Pneumatic or electric button to be defined in work.